

CALUMMA™ REMOTE S MC

Featuring an optical design using three high efficacy multi-chip LEDs and available with optional LED colour variants and various beam angles, the small-sized Calumma Remote S MC luminaire creates powerful and beautiful light output for a spot, accent or flood lighting solution. Its durable housing is built to withstand any exterior conditions, and its special finish for harsh and marine environments provides an exceptional outdoor LED luminaire in an elegant design. Complemented by a wide range of accessories, control protocols and connection options, this luminaire is an effective and versatile tool to get the most out of architectural lighting applications.



KEY FEATURES

Lumen output & Light source

Luminaire with three high-power, multi-chip LEDs provides up to 993 lumen output. Multiple LED colour variants. No light spills. Perfectly homogenised light output with efficacy up to 33 lm/w.

Design & Durability

Compact, durable and stylish housing made of high-pressure die cast aluminium. IP67 and IK10 certification; suitable for marine applications (Harsh Environment Finish required) and traffic applications. Supported with a 5 year warranty.

Flexibility

Exceptional outdoor or indoor LED luminaire with a wide range of accessories, custom colour finishes, multiple light output variants and beam angles.

COLOURS

* UPON REQUEST



RGBW



RGBA



Pure White



Tuneable White *

COLOUR TEMPERATURE

* UPON REQUEST



3.000 K



3.000 K
-
6.500 K *

CONTROL & PROTOCOLS



E-BOX
REMOTE
RANGE

STANDARD & SPECIFICATION



IP67



IK10



CE



ETL



ROHS



UK
CA



5
YEAR



Vibration
Standard
for Bridge

Warranty
with
Registration

Vibration
Standard
for Bridge

FINISH OPTIONS



Graphite
Black



Silver



RAL
Custom
Paint
Colour



Harsh
Environment

OPTIC OPTIONS

SYMMETRICAL



9°



15°



25°



30°



45°



65°



100°

BI-SYMMETRICAL



10°x30°



10°x60°



15°x45°



15°x90°



30°x60°



30°x90°

CALUMMA REMOTE S MC SPECIFICATION

ELECTRICAL	Input Voltage	48 V
	Typical Power Consumption	30 W +/-10 %
OPTICAL	Light Source	High Power Multichip LEDs
	Colour Variants	RGBW (W - 6500 K) RGBA PW (W - 3000 K) Other Variants On Request (TW 3000 - 6500 K)
	Beam Angle	9° 15° 25° 30° 45° 65° 100° 10°x30° 30°x10° 10°x60° 60°x10° 15°x45° 45°x15° 15°x90° 90°x15° 30°x60° 60°x30° 30°x90° 90°x30°
	Lumen Output Delivered	993 lm (@9° RGBW)
	Projected Lumen Maintenance	L90B10 >90.000 hrs, Ta = 25°C / 77°F
CONTROL	Interface Protocol	Via E-box Remote, E-box Remote Basic or E-Box Remote Basic Mini
	E-Box Remote control protocol	USITT DMX512/RDM, ArtNet, MA Net, MA Net2, sACN, Kling-Net
	Settings / Addressing	Via Two Row LCD Display with Control Buttons on E-Box Remote or RDM communicator
	Power Supply	Via E-Box Remote range
PHYSICAL	Width x Height x Depth	189 x 196 x 119 mm (7.4 x 7.7 x 4.7 in.)
	Weight	2.95 kg 6.5 lbs
	Housing	High Pressure Die-Cast Aluminium Body Tempered Glass
	Finish Options	Standard Colour - Graphite Black (RAL 9011) Silver (RAL 9006) Cost Option - Custom RAL Harsh Environment (RAL 9016, RAL 9011)
	Cables / Connections	IN - 1 m cable with bare end - Other cable length - custom - Junction box - optional
	Mounting Method	Yoke or Yoke for Pole Adaptor
	Adjustability	+180° / -180°
	Protection Factor	IP67 / Suitable For Wet Locations
	IK Rating	IK10
	Cooling System	Convection
Operating Ambient Temperature	-20 °C / +50 °C (-4 °F / +122 °F)	
CERTIFICATION	Listings	ETL / cETL, CE, RoHS, UKCA
ACCESSORIES	Not Included Items	
		Junction Box for Calumma XS
		Optical Demo Set for Calumma S
		Top Hat Calumma S
		Half Top Hat Calumma S
		Tenon Adaptor for Calumma S
		Floor Stand for Calumma S, M Pole Adaptor (ø 102mm) (Yoke for Pole Adaptor Required)

PROJECTED AREA

	Front (rear) - m ²	Front (rear) ft ²	Side - m ²	Side - ft ²	Top - m ²	Top - ft ²
Calumma S	0,023	0,250	0,019	0,207	0,018	0,196
with Top Hat	0,023	0,250	0,027	0,290	0,027	0,290
with Half Top Hat	0,023	0,250	0,022	0,232	0,027	0,290

DIMENSIONS

Standard Yoke

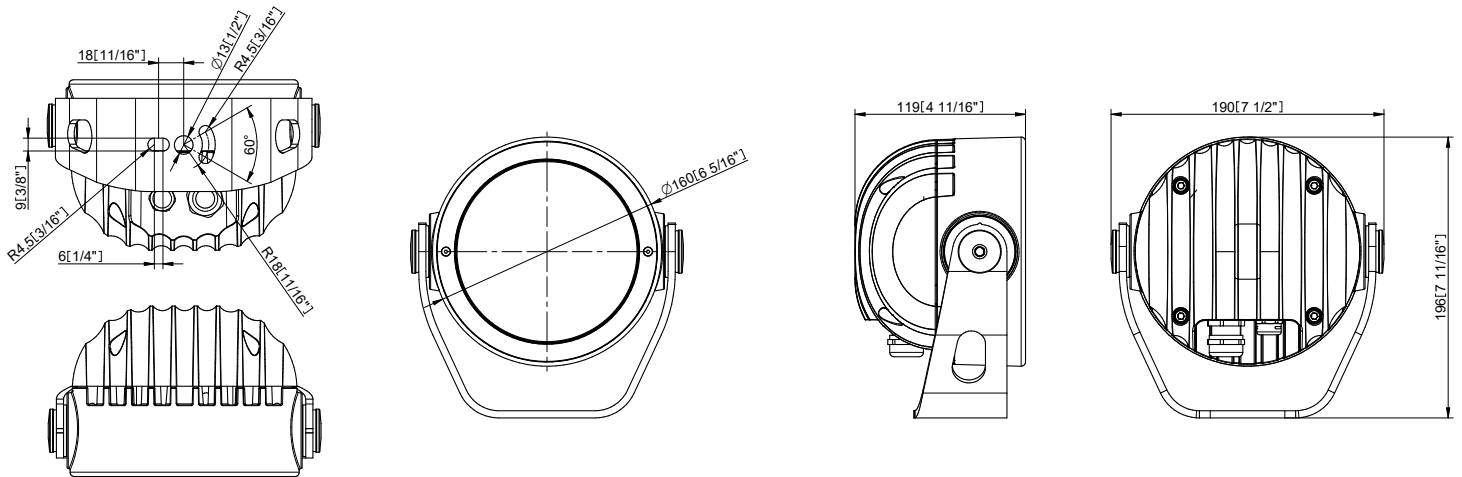

Yoke for Pole Adaptor (with Pole Adaptor / PA)

Example of ordering code: Calumma Remote S MC RGBCW 15° PA

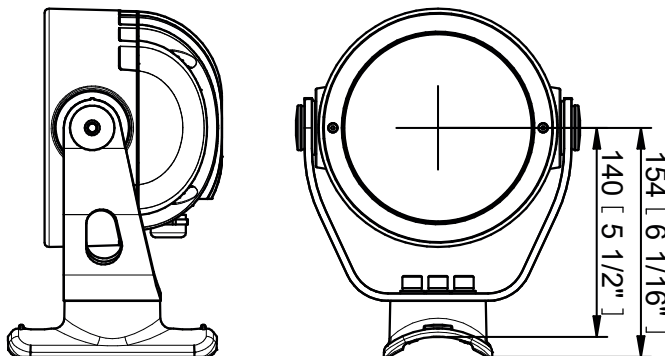

ACCESSORIES

Top Hat

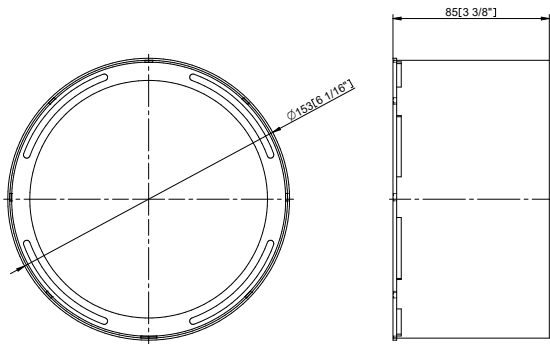

Half Top Hat

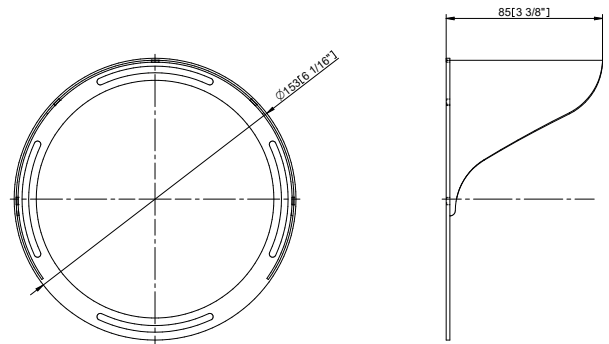

Floor Stand

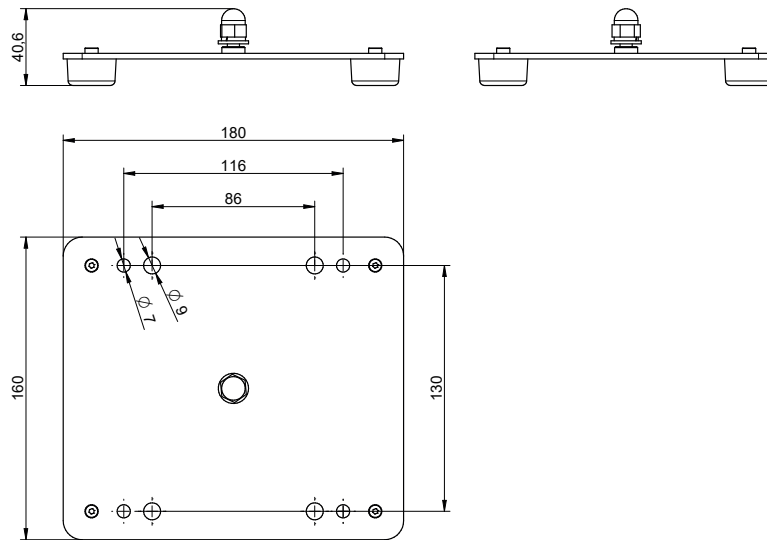

Pole Adaptor

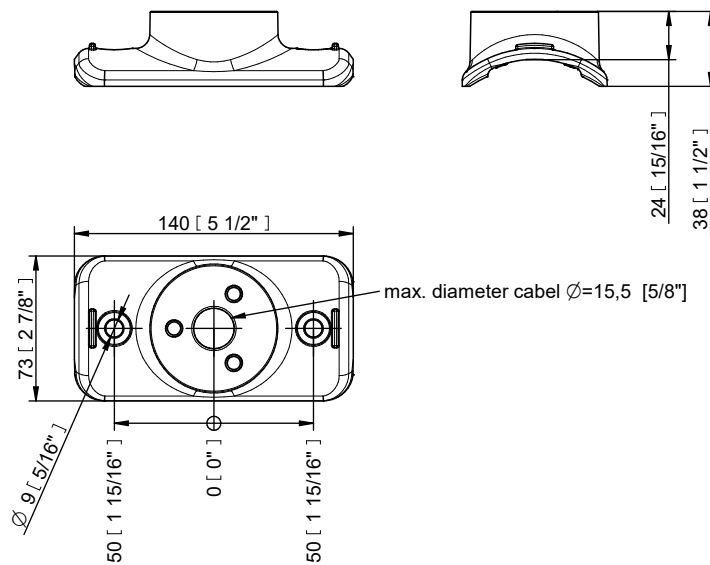

BI-SYMMETRICAL BEAM ANGLES

Bi-symmetrical:
10°x30°,
10°x60°,
15°x45°,
15°x90°,
30°x60°,
30°x90°

Bi-symmetrical:
30°x10°,
60°x10°,
45°x15°,
90°x15°,
60°x30°,
90°x30°

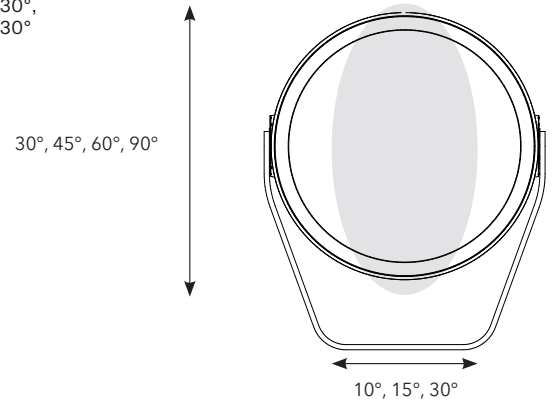
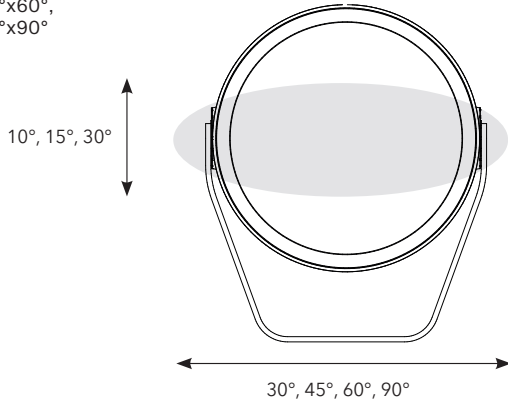

PHOTOMETRIC OVERVIEW

Lumen Output (lm)

	RGBCW (W 6500 K)	RGBA	WW (W 3000 K)
9°	993	852	847
15°	768	659	655
25°	762	653	650
30°	751	644	640
45°	761	653	649
65°	761	653	649
100°	753	646	642
10° x 30°, 30° x 10°	720	617	614
10° x 60°, 60° x 10°	800	686	682
15° x 45°, 45° x 15°	815	699	695
30° x 60°, 60° x 30°	757	649	645
30° x 90°, 90° x 30°	816	700	696
15° x 90°, 90° x 15°	904	773	769

CONNECTION

The table states max. number of Calumma Remote S modules connected to the E-box Remote or Remote Basic.

Cable length (m)	Max. number of Calumma Remote S connected to the E-Box Remote or Remote Basic
	CALUMMA REMOTE S
25	13
50	10
75	8
100	6

CONTROL AND CONNECTION OPTIONS

Via E-Box REMOTE (Calumma Remote S)

- 1) SJTW 5x 14AWG (1305 3336), black or On request Cable SJTW 5x 14AWG (13053697), white
- 2) Junction Box for Calumma XS, (4x Output)
- 3) UL 20969 5x 20AWG (13053481), black or On request Cable SJTW 5x 20AWG (13053696), white
- 4) Junction Box for Calumma XS, (1x Output)

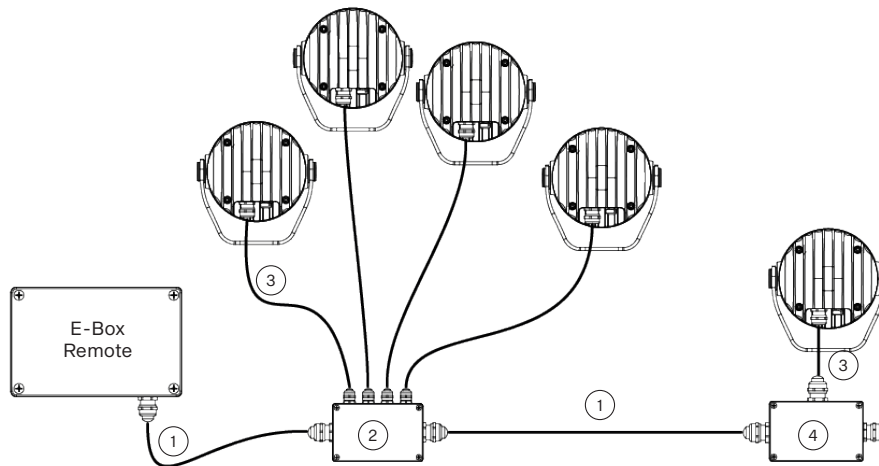

Via E-Box REMOTE (Calumma XS, Calumma Remote S, Eminere Remote)

- 1) SJTW 5x 14AWG (1305 3336), black or On request Cable SJTW 5x 14AWG (13053697), white
- 2) Junction Box for Calumma XS, (4x Output)
- 3) UL 20969 5x 20AWG (13053481), black or On request Cable SJTW 5x 20AWG (13053696), white
- 4) Junction Box for Calumma XS, (1x Output)

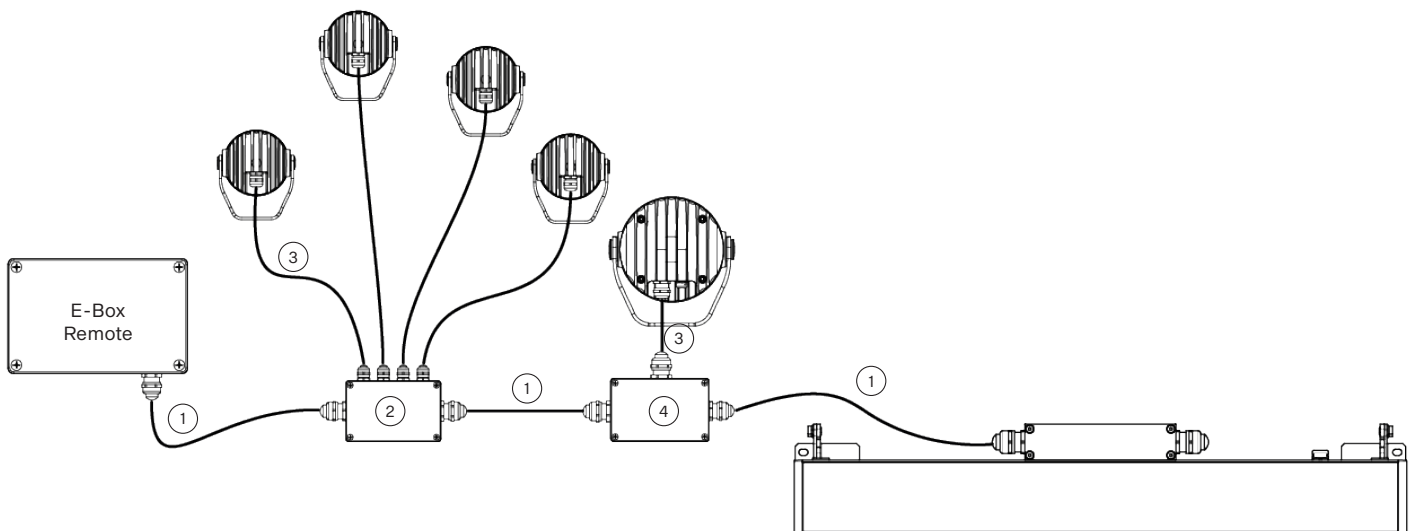

PHOTOMETRIC DATA

Calumma S MC RGBW 6500K 10dg

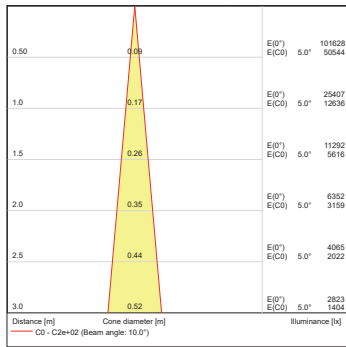
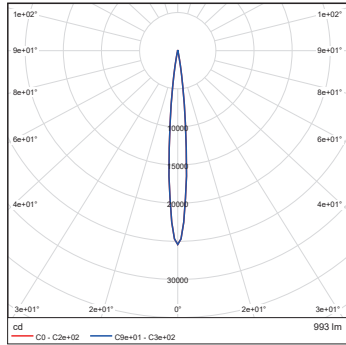

Calumma S MC RGBW 6500K 15dg

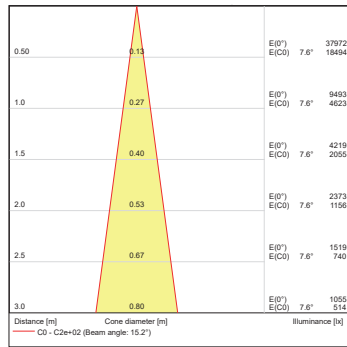
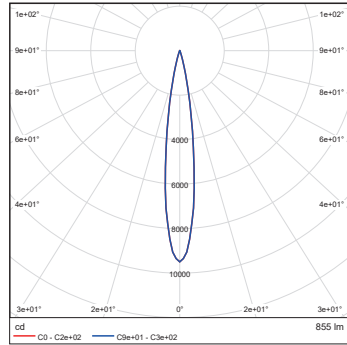

Calumma S MC RGBW 6500K 25dg

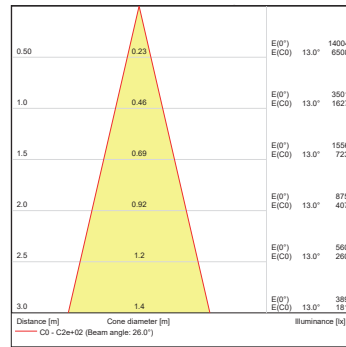
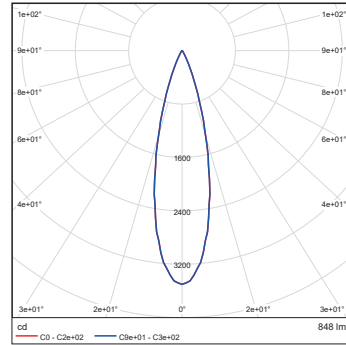

Calumma S MC RGBW 6500K 30dg

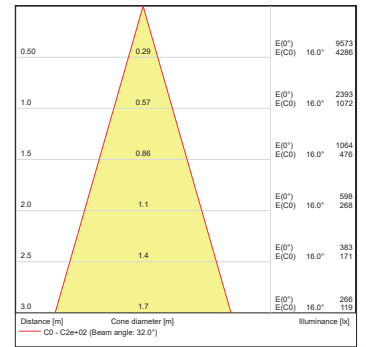
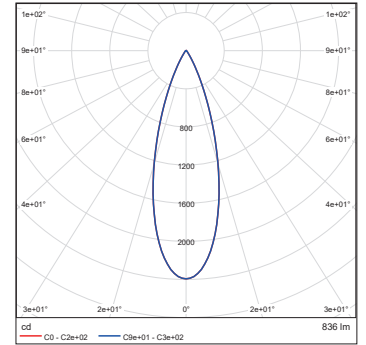

Calumma S MC RGBW 6500K 45dg

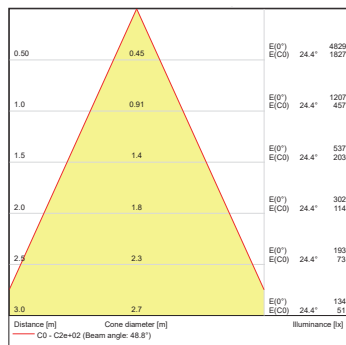
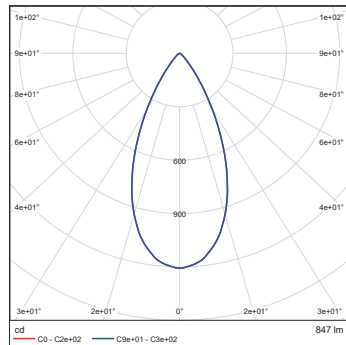

Calumma S MC RGBW 6500K 65dg

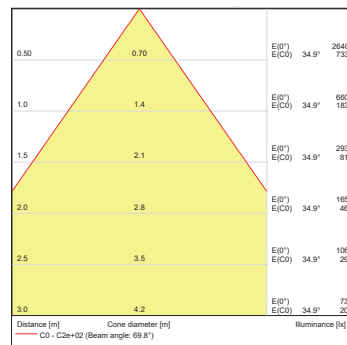
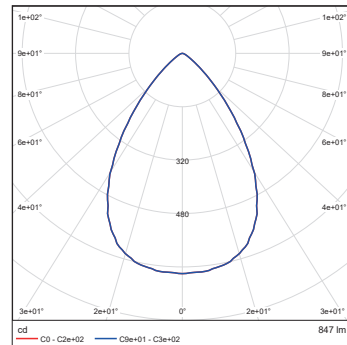

Calumma S MC RGBW 6500K 100dg

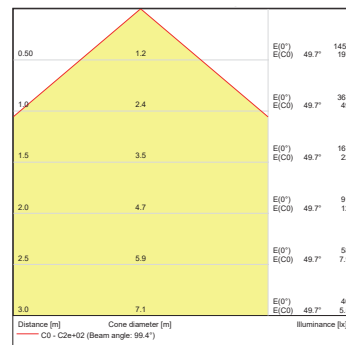
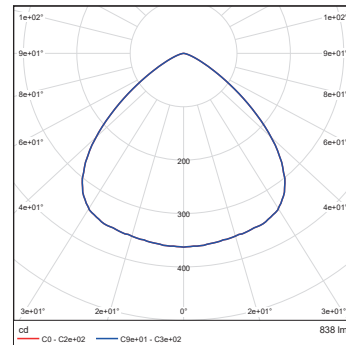

PHOTOMETRIC DATA

Calumma S MC RGBW 6500K
10x30dg

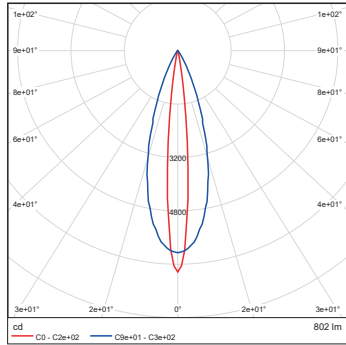

Calumma S MC RGBW 6500K
10x60dg

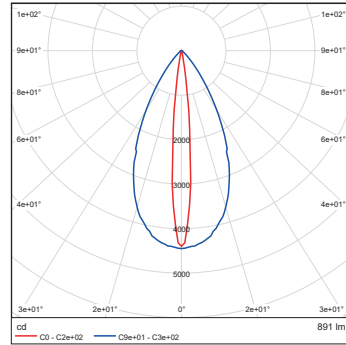

Calumma S MC RGBW 6500K
15x45dg

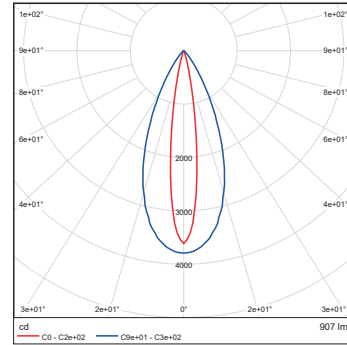

Calumma S MC RGBW 6500K
15x90dg

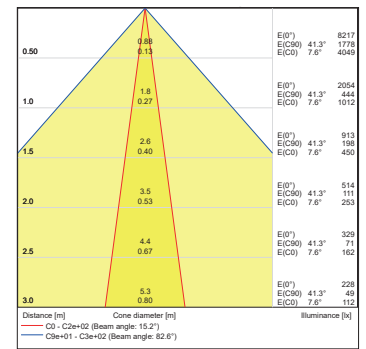
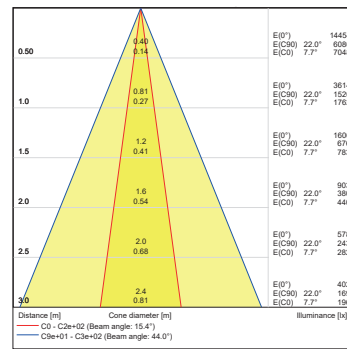
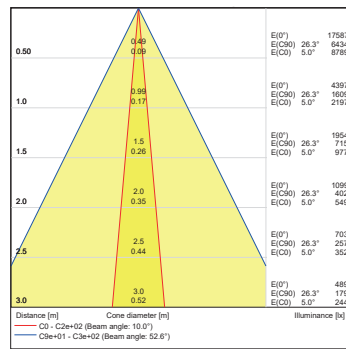
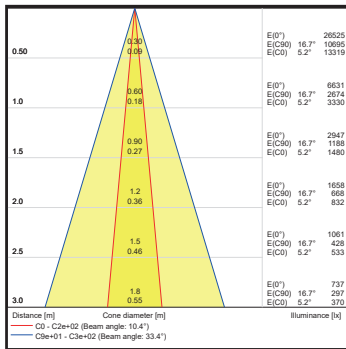
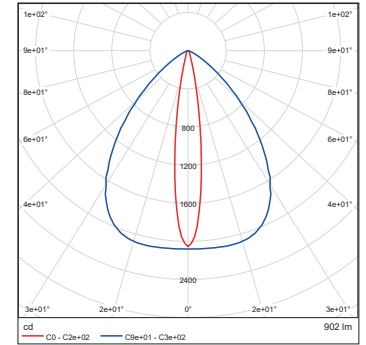

Calumma S MC RGBW 6500K
30x60dg

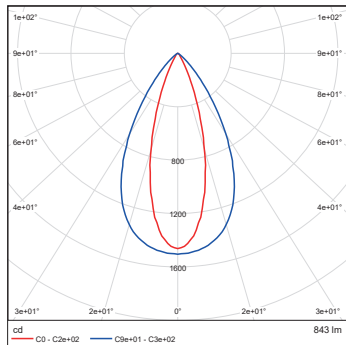

Calumma S MC RGBW 6500K
30x90dg

