

QR code for Installations Instructions



Fixture must be installed by a qualified electrician in accordance with all national and local electrical and construction codes and regulations.



**STEP 1**  
**INSTALL HOUSING**

1

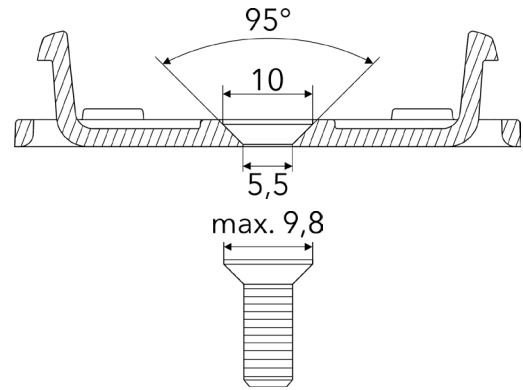
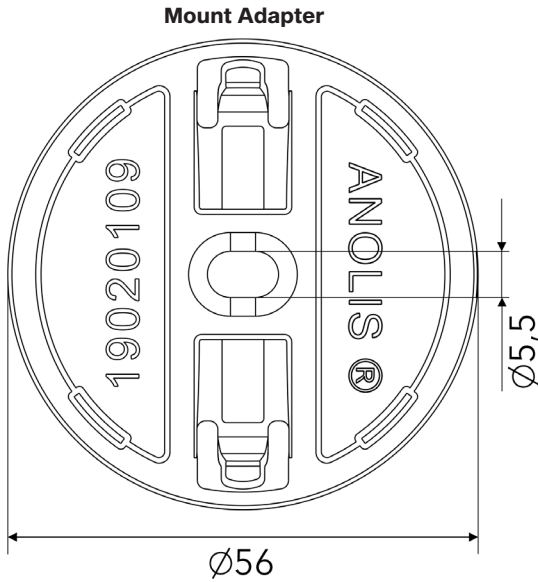

Drill hole to the mounting surface according to mount adapter holes spacing.

Length, diameter and type of screw depends on conditions of installation. The head of the screw should not be sticking out of the mount adapter. Otherwise, the ArcPix II may not seat properly in the mounting adapter.

2

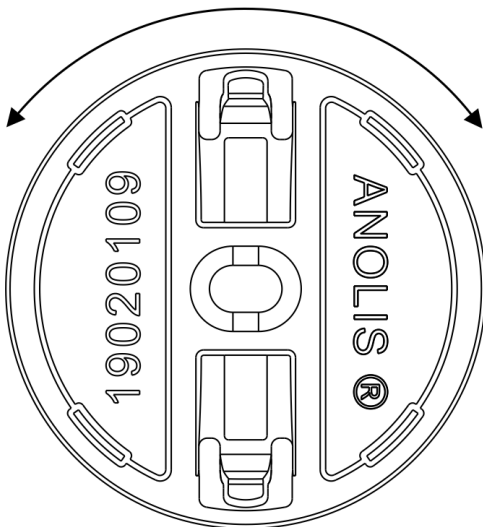

Prepare the correct mounting position of the adapter, making sure that all of them are oriented in the same direction.

3

Use fasteners that are appropriate for use with your mounting surface.

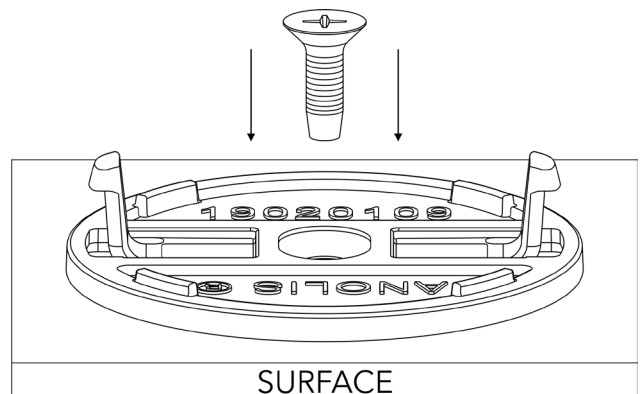

Take care not to over tighten the fastener to avoid damaging the mounting adapter.

**STEP 2  
INSTALL LUMINAIRE**

⚠ Never screw the ArcPix II directly on the surface without using the mounting adaptor. ⚠

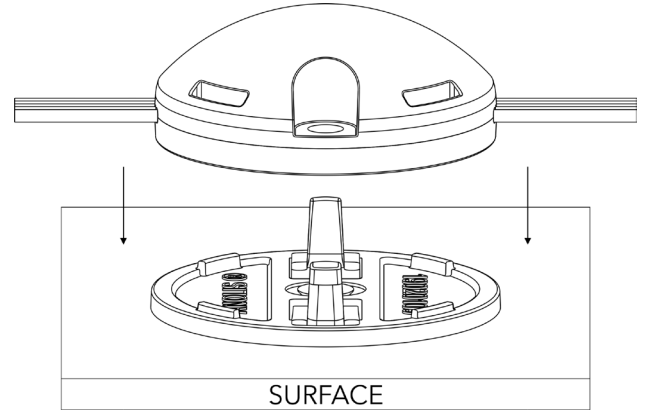
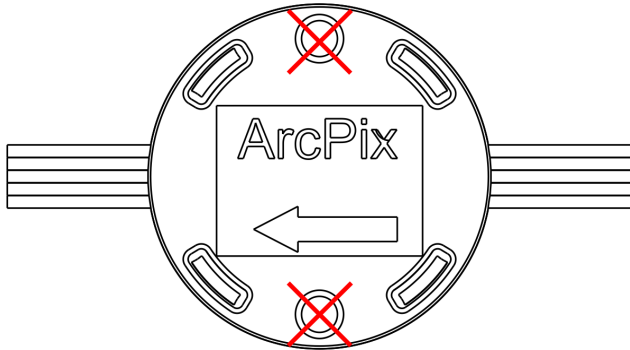

Snap the ArcPix II into the mount adaptor.

Every ArcPix II has an identification label with arrow on the bottom side. When you do your installation, keep the same orientation of the ArcPix II lines to ensure the same light characteristic of each line.

**STEP 3  
CONNECT LUMINAIRE**

⚠ Maximum length between the Arc Power and the last ArcPix II must not exceed 100 meters. Do not connect or disconnect the ArcPix II strings with the ArcPixel power/ArcPower Unit Pixel energized. ⚠

1A

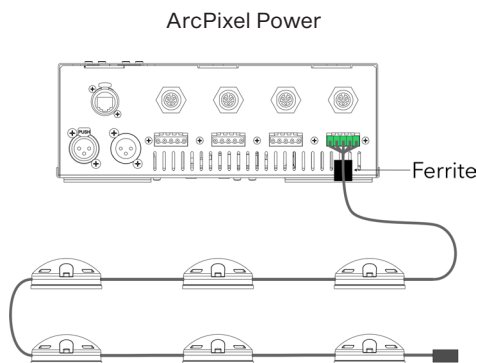

1B

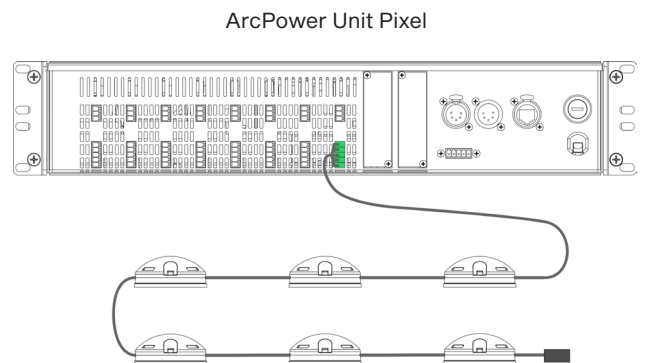

Install terminal blocks on cable and connect it to the LED outputs of the ArcPixel Power.

Install terminal blocks on cable and connect it to the LED outputs of the ArcPower Unit Pixel.

The ferrite with one turn of the flat cable has to be placed on the cable at each ArcPix II output of the ArcPixel Power, and this ferrite (without cable turn - cable goes directly through ferrite, ferrite cover is snapped only) has to be placed after each thirtieth ArcPix II in the ArcPix II line (e.g. 100 ArcPixes II per output = 3 ferrites in a line + 1 ferrite with a cable turn at the ArcPix II output). You should count 100mm of the cable length per one cable turn on ferrite. The ArcPix II line ferrites (between ArcPixes II) have to be placed on the flat cable before mounting of ArcPixes II on an installation surface.

## STEP 4 TERMINATION BOX

The last ArcPix II in the daisy chain has to be ended by the termination box.

1

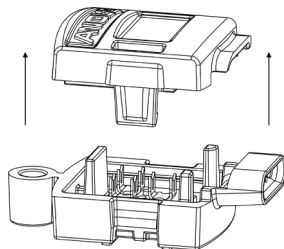

Remove the front cover from termination box.

2

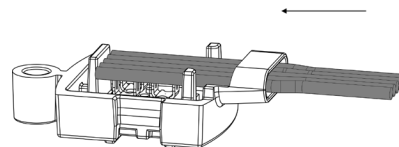

Separate wire cores from isolation at length cca 40 mm on the end of the 5-wire flat cable. Insert the 5-wire flat cable through the bushing into the base of the termination box until it touches the partition in the termination box and align the cores into cutting edges.

3

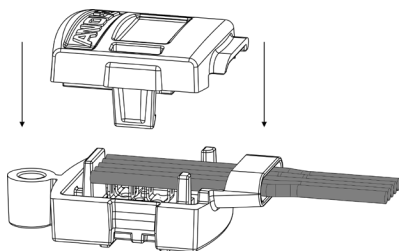

Put the cover on the base and press both parts together until both plastic catches snap into slots in the base of the termination box. For pressing use suitable plier with flat jaws if necessary.

4

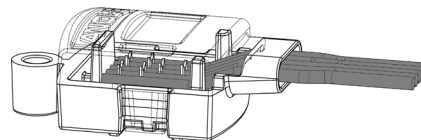

The cable cores are pressed by the cover and pushed to the contacts in base.

5

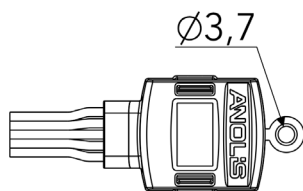

The hole in the housing of the termination box serves for screwing to the mounting surface.

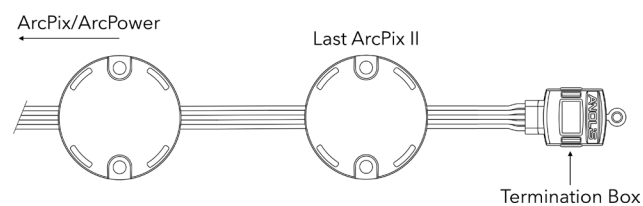

### STEP 5 REPLACING THE ARCPIX II

In case that some ArcPix II in a chain is faulty, cut it off and use the new ArcPix II and two connection boxes to repair faulty ArcPixel II in the chain.

1

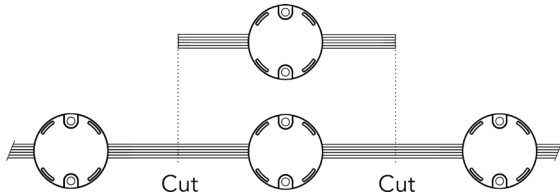

Cut away the faulty ArcPix II (carefully check the length of the new ArcPix II cable).

2

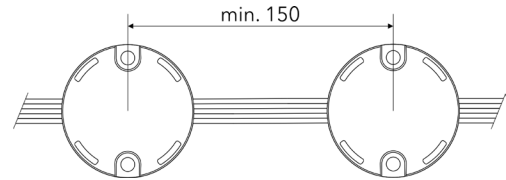

The minimum distance between ArcPix II centers is 150 mm.

3



Check the correct position orientation of the new ArcPix II before connecting it into connection boxes.

4

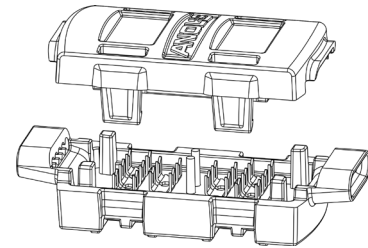

Remove the front cover from connection box.

5

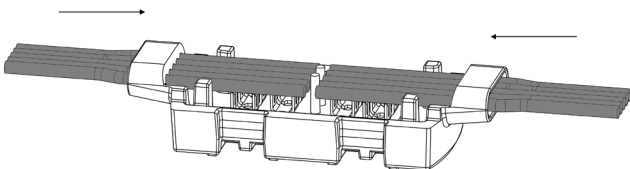

Separate cores in length 40 mm on the end of 5-wire flat cable. Insert cable trough the bushing into base of the connection box until it touches the partition in the connection box and align the cores into cutting edges.

6

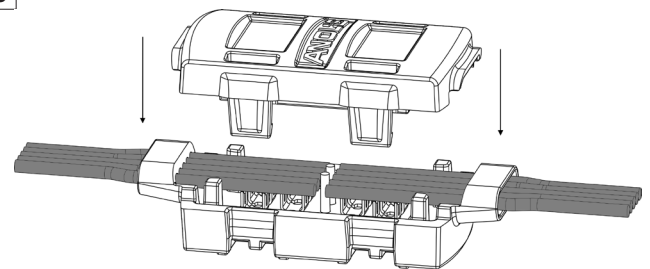

Put the cover on the base and press both parts together until four plastic catches snap into slots in the base of the termination box. For pressing use suitable plier with flat jaws if necessary.

7

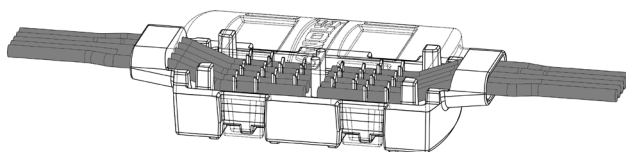

The cable cores are pressed by the cover and pushed to the

